



A-DEC 500™ Owner's Guide

# ASSISTANT'S INSTRUMENTATION



A-dec 500 Assistant's Instrumentation  
Owner's Guide

---

## Copyright

Copyright © 2006 A-dec Inc. All Rights Reserved.

2601 Crestview Drive, Newberg, OR 97132 USA

Printed in USA.

A-dec Inc. makes no warranty of any kind with regard to the content of this document, including but not limited to, the implied warranties of merchantability and fitness for a particular purpose. A-dec Inc. shall not be held liable for any errors contained herein or any consequential or other damages concerning the furnishing, performance, or use of this material. The information in this document is subject to change without notice. If you find any problems with this document, please report them to us in writing. A-dec Inc. does not warrant that this document is error-free.

All other non A-dec products or services mentioned in this document are covered by the trademarks, service marks, or product names designated by the companies marketing those products.

## Trademarks

A-dec 500, A-dec logo, Cascade, Cascade Master Series, Century Plus, Continental, Decade, Performer, Preference, Preference Collection, and Radius are A-dec trademarks registered in the U.S. Patent and Trademark office.

A-dec, A-dec 500 and ICX are also trademarks of A-dec Inc.

[www.a-dec.com](http://www.a-dec.com)

## Warranty

Use this box to log your equipment information.

Warranty Information
Serial number
Model number
Date purchased

A-dec™ warrants all products against defects in material or workmanship for one year from time of delivery. A-dec's sole obligation under the warranty is to provide parts for the repair, or at its option, to provide the replacement product (excluding labor). The buyer shall have no other remedy. (All special, incidental, and coincidental damages are excluded.)

Written notice of breach of warranty must be given to A-dec within the warranty period. The warranty does not cover damage resulting from improper installation or maintenance, accident or misuse. The warranty does not cover damage resulting from the use of cleaning, disinfecting or sterilization chemicals and processes. The warranty also does not cover light bulbs. Failure to follow instructions provided in A-dec's Owner's Guide (operation and maintenance instructions) may void the warranty.

A-dec warrants A-dec dental chair cylinders, both lift and tilt, for ten years from the date of purchase of the chair or the cylinder. This warranty is retroactive to A-dec chair cylinders already in the field. The warranty covers chair cylinders A-dec finds to have manufacturing related irregularities. Stool cylinders are covered under A-dec's one-year warranty.

No other warranties as to merchantability or otherwise are made.

For service information contact your local authorized A-dec dealer.

Check with local codes and ADA (Americans with Disabilities Act) requirements for installation of this product.

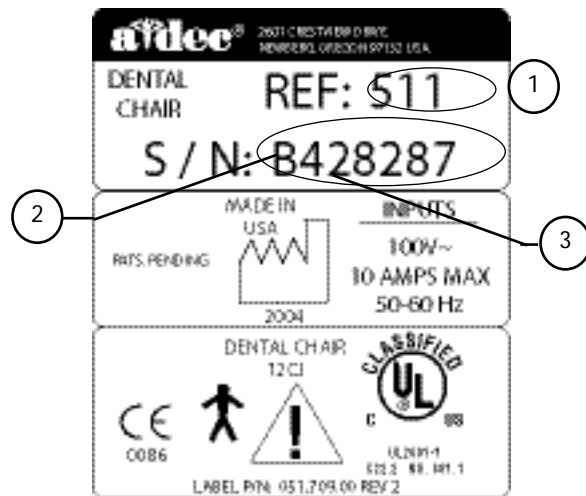











### Serial Number Identification

1 - Model number; 2 - The first letter of the serial number indicates the month the product was manufactured; (e.g., B is February); 3 - First digit indicates the year of manufacture (e.g., 4 is 2004).

A	January	G	July
B	February	H	August
C	March	I	September
D	April	J	October
E	May	K	November
F	June	L	December

**CAUTION:** Federal law restricts this device to sale by or on the order of a dentist, physician or any other practitioner licensed by the law of the state in which he or she practices to use or order the use of the device.

## Identification of Symbols

SYMBOL	DESCRIPTION
	Recognized by Underwriters Laboratories Inc. with respect to electric shock, fire and mechanical hazards only in accordance with UL 60601-1 (2601-1) and under mutual recognition agreement with CAN/CSA C22.2, No. 601.1.
	Classified by Underwriters Laboratories Inc. with respect to electric shock, fire and mechanical hazards only in accordance with UL 60601-1 (2601-1) and under mutual recognition agreement with CAN/CSA C22.2, No. 601.1.
	UL listed to UL 61010A-1, BS EN 61010-2-010 and Canadian (CAN/CSA C22.2, No. 1010.1-92) safety standards.
	Conforms to applicable European Directives (refer to Declaration of Conformity).
	Protective earth (ground).
	Functional earth (ground).
	Attention, consult accompanying documents. No user serviceable parts. Attention, line voltage. Only licensed electrician should remove cover.
	Type B applied part.
	Class II equipment.
	Caution: Metal surfaces can be hot during and following the dry cycle.

## Electrical Rating

TYPE	SPECIFICATION
Volts:	100/110-120/220-240 VAC
Frequency:	50-60 Hz
Current:	As configured and specified in equipment manual (products labeled 15A or greater require dedicated circuit, identified in distribution panel).

## Classification of Equipment (EN-60601-1)

TYPES/MODE	CLASSIFICATION
Types of shock protection	CLASS I EQUIPMENT: Dental chairs, dental lights, and power supplies  CLASS II EQUIPMENT: Chair, wall, and cart-mounted delivery systems
Degree of shock protection	TYPE B APPLIED PART: Delivery systems only
Degree of protection against water ingress	ORDINARY EQUIPMENT: All products
Mode of operation	CONTINUOUS OPERATION: All models except dental chairs  CONTINUOUS OPERATION WITH INTERMITTENT LOADING: Dental chairs - 5% duty cycle
Flammable gasses:	Not suitable for use in the presence of a flammable anesthetic mixture with air, oxygen, or nitrous oxide, where such gasses may accumulate in concentration (closed space).

## Environmental Specifications

TEMPERATURE/HUMIDITY	SPECIFICATION
Storage/Transportation	Temperature: -40C to 70xC (-40xF to 158xF)  Relative humidity: 80% for up to 31xC, decreasing linearly to 50% at 40xC.
Operating	Temperature: 10xC to 40xC (40xF to 104xF)  Relative humidity: 80% for up to 31xC, decreasing linearly to 50% at 40xC.
Indoor Use:	Altitude up to 2,000M (6,563 ft.), installation category II, pollution degree 2.  (UL 61010A-1 and CAN/CSA C22.2, No. 1010.1-92 only)

## Table of Contents

Welcome .....	1
Intended Audience .....	1
About This Document .....	1
Conventions .....	1
How to Use This Guide .....	1
About Your Assistant's Instrumentation .....	2
How to Operate Your Assistant's Instrumentation .....	2
On/Off Switch .....	2
Instruments .....	3
How to Maintain the Solids Collector .....	5
Limit Switches .....	5
How to Position Your Assistant's Instrumentation .....	6
Short Assistant's Arm .....	6
Long Assistant's Arm .....	6
Holder Assembly .....	6
Adjustable Holders .....	7
Dual Holder Assemblies .....	7
Electric Holders .....	7
Assistant's Touchpad .....	7
Left/Right Conversion .....	7
How to Operate Your Standard Touchpad .....	8
Manual Chair Controls .....	8
Program Button .....	8
Position 0 (Entry/Exit) .....	8
Positions 1 and 2 .....	8
Position 3 .....	9
Cup Fill .....	9
Bowl Rinse .....	9
A1/A2 Buttons .....	9
Light .....	10
Care Instructions .....	11
Touch and Transfer Surfaces .....	11
Heat Sterilization .....	11
Specifications .....	11

## Tables

Table 1 – Steps for HVE and Saliva Ejector Asepsis ..... 4  
Table 2 – Steps for Sterilizing the HVE Tip ..... 4

## Illustrations

Figure 1 – Parts of the Assistant's Instrumentation ..... 2  
Figure 2 – Solids Collector ..... 2  
Figure 3 – Left/Right-Hand Conversion of the Autoclavable HVE and Saliva Ejector ..... 3  
Figure 4 – Removing the Solids Collector Screen ..... 6  
Figure 5 – Rotation of the Holder Assembly ..... 6  
Figure 6 – Positioning Individual Holders ..... 7  
Figure 7 – Functions of Standard Touchpad ..... 8

## About this Document

### Welcome

Welcome to the A-dec 500 Assistant's Instrumentation Owner's Guide. This guide provides an easy to use source of technical information for servicing and maintaining your assistant's instrumentation.

### Intended Audience

This guide is intended for doctors and dental staff to use when operating and maintaining A-dec 500 assistant's instrumentation.

## About this Document

This document contains

- instructions on left/right conversion of a HVE and saliva ejector
- maintenance procedures for the solid collector
- detail on the functions of the touchpad, and
- product specifications.

## Conventions

A number of items and instructions appear throughout this document. The formatting conventions are designed to make it quick and easy to find and understand information.

- References to sections, or reference documentation appear in italic type, e.g., *How to Operate the Delivery System*.
- Important supplemental information about the covered topic appears as a note, e.g.,  
**NOTE:** The foot control also has . . . .
- Bubble numbers, callouts, and tables identify key components in an illustration.

## How to Use this Guide

This guide provides detailed descriptions and operation instructions for the use of the A-dec 500 assistant's instrumentation. Before using the assistant's instrumentation, review this document to get a feel for the capabilities of the assistant's instrumentation and its to operation. Make note of all cautions and warnings.

## About Your Assistant's Instrumentation

A-dec's standard assistant's instrumentation package includes autoclavable syringe, HVE, and saliva ejector. Optional instruments may include an additional HVE. The solids collector is also a part of the assistant's instrumentation, located at the end of the assistant's instrumentation arm.

The assistant's vacuum instruments are fully autoclavable and have quick disconnect attachments that are easily removed for cleaning.

## How to Operate Your Assistant's Instrumentation

### On/Off Switch

There are two power source locations for the assistant's instrumentation, the Power On/Off button on the chair and the delivery system master On/Off toggle.

### Power On/Off Button

The Power On/Off button is located on the base of the chair. This function allows you to engage power or disengage power to the entire system at the touch of a button. When the button is pressed in, the system has power. When the button is out, the system has no power.

### Delivery System Master On/Off Toggle

The master On/Off toggle, located on the right side of the control head, controls the utilities for the delivery system as well as other modules mounted to the chair.

**CAUTION:** For prolonged life of your equipment, turn power OFF when not in use.

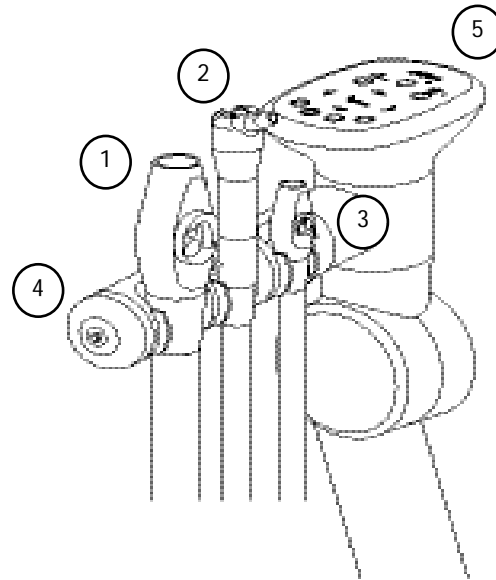

Figure 1 **Parts of the Assistant's Instrumentation.**

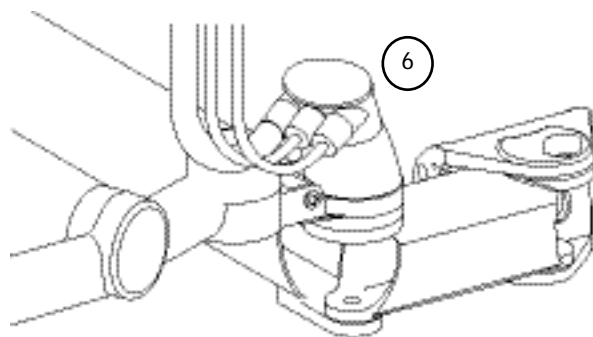

Figure 2 **Solids Collector.**

- 1 - Autoclavable HVE; 2 - Autoclavable syringe;
- 3 - Autoclavable saliva ejector; 4 - Holder assembly;
- 5 - Touchpad; 6 - Solids Collector

## Instruments

### Autoclavable Syringe

For information on the operation, care, and maintenance of A-dec's autoclavable syringe, refer to your Autoclavable Syringe Owner's Guide (P/N 85.0680.00).

### Autoclavable HVE and Saliva Ejector

The autoclavable HVE and saliva ejector are equipped with a quick disconnect to remove the valve body from the tubing for cleaning and autoclaving.

### Left/Right-Hand Conversion of the Autoclavable HVE and Saliva Ejector

The HVE and saliva ejector can be easily converted for operation from either side of the chair.

To convert the HVE or saliva ejector to one side or the other, push the control valve out of the HVE body, by pressing on the small diameter side. Rotate the control valve 180°, then push it back into place.

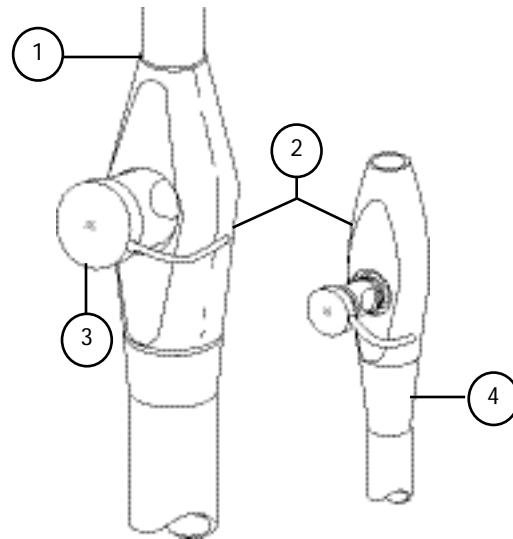

Figure 3 **Left/Right-Hand Conversion of the Autoclavable HVE and Saliva Ejector.**

1 - Cannula opening (for tip); 2 - Valve body;  
3 - Control valve; 4 - Tailpiece

Autoclavable HVE and Saliva Ejector Asepsis

The table shows the steps for HVE and saliva ejector asepsis.

**Table 1 Steps for HVE and Saliva Ejector Asepsis**

Step	Action
1	Remove the tip from the valve body. NOTE: Turn OFF the central vacuum before disconnecting the HVE or saliva ejector.
2	To remove the HVE or saliva ejector body, separate the body from the tubing by pulling it apart at the tailpiece.
3	Remove the control valve by pushing it out of the HVE or saliva ejector valve body.
4	Clean and rinse the valve body and control valve using a mild detergent, water, and the brushes that have been provided. Allow the instruments to dry completely.
5	Heat sterilize the valve body and control valve for 6 minutes using either of the following methods: steam autoclave, or chemical vapor (275°F [135°C] maximum temperature).
6	Apply a light coat of A-dec silicone lubricant on the O-ring seals of the control valve. CAUTION: Use only silicone lubricant when lubricating instrumentation O-rings. Petroleum products will cause permanent damage to the O-rings.
7	Reinstall the control valve in the valve body, and the body on the tubing tailpiece.
8	Operate the HVE and the saliva ejector valves several times to verify that they rotate smoothly.

How to Sterilize the HVE Tip

It is recommended that the stainless steel tips used on the HVE be heat sterilized between patients using either sterilizers of the following methods: steam autoclave, or chemical vapor (275°F [135°C] maximum temperature; four minutes at temperature). If you are using disposable HVE tips, be sure to replace them with new tips between patients.

The table shows the steps for sterilizing the HVE tip.

**Table 2 Steps for Sterilizing the HVE Tip**

Step	Action
1	Remove the HVE tip from the HVE valve body.
2	Clean and rinse the HVE tip using a mild detergent and water, then allow the tip to completely dry.
3	Sterilize the HVE tip using one of the recommended methods.

NOTE: A-dec HVE Cannula Opening: Standard A-dec HVE - 0.435" ± 0.006" (11.05 ± 0.15 mm). A-dec 15 mm HVE - .592" (14.8 mm). If not using A-dec HVE Tips, select a tip that is compatible with your HVE cannula opening.

A-dec Saliva Ejector Cannula Opening: A-dec Saliva Ejector - 0.265 ± 0.006" (6.73 ± 0.15 mm)

Select a tip that is compatible with your saliva ejector cannula opening.

### How to Maintain the Solids Collector

The solids collector aids in preventing solids from entering the central vacuum system.

At least twice a week, discard and replace the solids collector screen. This is necessary to ensure proper suction from the central vacuum, and to maintain proper treatment room asepsis. For replacement screens, contact your Authorized A-dec Dealer and reference Pinnacle P/N 5512.

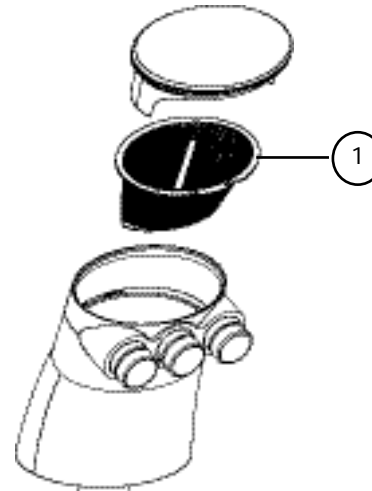

Figure 4 **Removing the Solids Collector Screen.**

1 - Solids collector screen

Follow these steps . . .	To perform this function . . .
1	Turn off vacuum, or if vacuum is on, open the HVE control valve to facilitate removal of the solids collector cap.
2	Remove the screen from the collector. The solids collector screen is disposable. Discard following your local regulations.  <b>CAUTION:</b> Do not empty the screen into your cuspidor. Doing so could plug the drain.
3	Insert a new screen in the solids collector and install the cap.

### Limit Switch

If activated, the support link limit switch will interrupt the base down motion and reverse the chair to prevent damage.

## How to Position Your Assistant's Instrumentation

The A-dec 500 assistant's instrumentation is equipped with either a short or long assistant's arm for easy positioning of instrumentation. Both arms are equipped with a touchpad and holder assemblies with individual holders for added positioning.

### Short Assistant's Arm

The short assistant's arm positions near the cuspidor or along side the chair back. It adjusts in a forward, backward, and side-to-side movement for easy positioning and access to the instrumentation.

A pivot joint located close to the support link, allows the entire arm to "tip-up," if forced, to minimize damage to the equipment if lowered on to an object.

The arm segment, attached to the touchpad, gives way downward if forced beyond its normal range of operation. Simply lift the arm back into place to reset and continue operation.

### Long Assistant's Arm

The long assistant's arm has the same features as the short arm, and can be positioned closer to the headrest. In addition, this arm accommodates variable height adjustment for multiple users.

### Holder Assembly

The holder assembly rotates completely for positioning to suit most procedures (see Figure 5).

**NOTE:** If you have electric holders, the holder assembly can be rotated 340 degrees only.

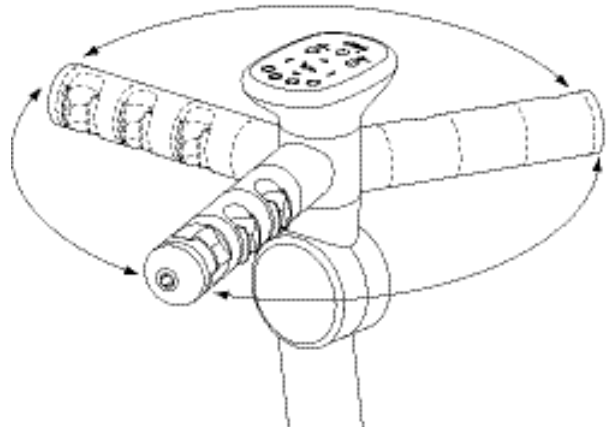

Figure 5 **Rotation of the Holder Assembly.**

### Adjustable Holders

The independently adjustable holders can be pivoted 340 degrees to allow customized positioning for each instrument on the holder assembly.

To rotate each holder, pull holder slightly away from the adjacent one, twist to the desired position and release (see Figure 6).

### Dual Holder Assemblies

Dual holder assemblies option gives the dental team the ability to offset or alternate the syringe, saliva ejector, and HVE placement. The additional holder assembly helps the assistant to comfortably differentiate and locate the instruments during the dental procedure.

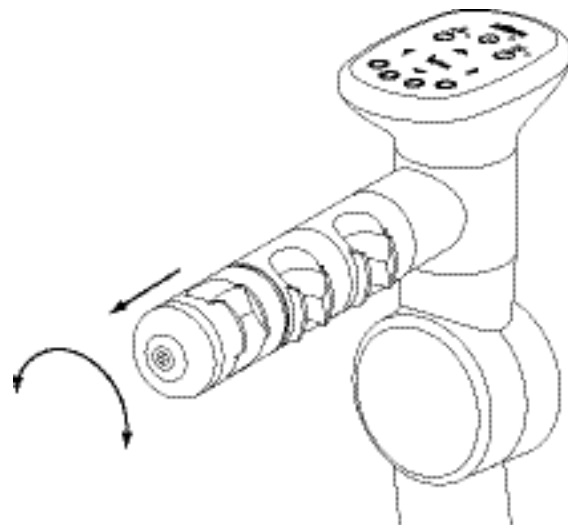

Figure 6 **Positioning Individual Holders.**

### Electric Holders

The optional electric holders provide vacuum On/Off switching for users whose vacuum system requires this functionality. When the HVE or saliva ejector is lifted from the holder, the vacuum pump will activate automatically. When placed back into the holder, the vacuum will be turned off.

### Assistant's Touchpad

A standard touchpad serves as a convenient handle rotating 340 degrees for easy access and visibility. The touchpad also provides a one touch surface for controlling the chair, dental light, and cuspidor/ A-dec relay module (a1, a2).

### Left/Right Conversion

Positioning the assistant's instrumentation to the opposite side of the chair can be done in a minimal amount of time. Loosen the support link locking screw located under the swivel brake handle, unsnap the support link back cover, and reposition the arm to the opposite side. Once the instruments are in place, reattach the support link cover, and tighten the support link locking screw finger tight.

## How to Operate Your Standard Touchpad

### Manual Chair Controls

The Base function controls chair lift, or vertical movement. To raise the chair, press the up arrow. To lower the chair, press the down arrow. Hold down the arrow until the chair reaches the desired height, then release it.

The Back function controls the chair back. To raise the chair back, press the right arrow. To lower the chair back, press the left arrow. Hold down the button until the chair back reaches the desired position, then release it.

### Program Button

Use the Program button located in between the arrows on the touchpad to save the settings for chair positions and cuspidor cup fill and bowl rinse times.

### Position 0 (Entry/Exit)

Pressing Entry/Exit (Position 0) sends the chair to a preset entry/exit position.

### Positions 1 and 2

Pressing Position 1 or 2 on the touchpad sends the chair base and back to a preset position.

Pressing this position . . .	Causes this action . . .
Entry/Exit (0)	Chair base and back move to the preset entry/exit position.
Position 1 or 2	Chair moves to a programmed operating position.
Position 3	Chair back moves to an x-ray/rinse position.



Figure 7 Functions on the Standard Touchpad.

Icon	Description
	Entry/exit
	Position 1
	Position 2
	Position 3 (x-ray/rinse)
	Program button
	Back down
	Base down
	Back up
	Base up
	Status icon
	Cup fill
	Bowl rinse
	a1 A-dec Relay Module
	a2 A-dec Relay Module
	Light

### Position 3

Position 3 is factory preset to an x-ray/rinse position. Pressing Position 3 moves the back to an x-ray/rinse position. A second press on the button returns the chair back to the operating position. This position can be changed to a programmable position like 1 and 2.

### Cup Fill

The cup fill function allows water to flow from the cuspidor into a cup. Tap the cup fill button for a timed operation, or hold for a manual operation.

### Bowl Rinse

The bowl rinse function provides rinse water for the cuspidor bowl. Tap the bowl rinse button for a timed operation, or hold for a manual operation.

If the bowl rinse button is pressed twice in less than two seconds, it will be set into a continuous operation. To stop the continuous bowl rinse operation, press the bowl rinse button once.

### A1/A2 Buttons

The a1/a2 buttons can be used to operate an A-dec relay module. For more details on the A-dec relay module, contact your authorized A-dec dealer.

**NOTE:** You can only operate an A-dec relay module with a standard touchpad if a cuspidor is not installed. You must upgrade to a deluxe touchpad, if you wish to operate an A-dec relay module and a cuspidor.

## Dental Light

The dental light button on the touchpad works as a three-way switch allowing you to turn the dental light on or off from either the touchpad or the dental light.

A quick press on the button allows you to toggle between three intensity settings, depending on the location of the dental light's intensity switch. The dental light can be toggled between composite and medium intensity settings or composite and high intensity settings. When the dental light is in the composite setting, the indicator light next to the button flashes.

The dental light also has an auto On/Off feature. When using a programmed chair position (1 or 2), the dental light will come on when the chair reaches an operating position. The dental light will turn off automatically when Position 0 (entry/exit) or Position 3 (x-ray/rinse) is pressed.

**NOTE:** If Position 3 has been reprogrammed to a programmable position, the dental light will not turn On/Off when Position 3 is pressed.

## How to Disable Factory Preset Functions

There are two factory preset options that can be turned On or Off from the standard touchpad.

### Dental Light (Auto On/Off)

Auto On/Off setting can be turned off by pressing and holding the Program button and then the Light button together for three seconds. One beep will confirm that the factory preset has been turned off. To return to the factory preset repeat steps. Three beeps will confirm that the auto On/Off function is on.

### Position 3 (X-ray/Rinse)

Position 3 can be toggled from the x-ray/rinse position to a programmed position. To program Position 3, press Program and then press and hold Position 3 together for three seconds. One beep confirms that the position can be programmed. To return to the x-ray/rinse position, repeat steps. Three beeps confirms that the x-ray/rinse function is on.

## Care Instructions

### Touch and Transfer Surfaces

Touch surfaces are those areas that require contact and become potential cross-contamination points during dental procedures. The minimum touch surface locations on A-dec 500 products include the touchpad(s), control head brake handles, and dental light handles and switches.

Transfer surfaces are those surfaces that are contaminated by contact with instruments and other inanimate objects. The primary transfer surfaces on the A-dec 500 product include traditional holders, Continental® instrument pad, and trays.

A-dec recommends barrier protection for all applicable touch and transfer surfaces. When used, barriers must be FDA market-cleared barrier plastic. Cover-All™ barrier film or any other FDA market-cleared barrier film is suitable for this application. Refer to your national regulatory authorities for barrier recommendations specific to your locale. Barrier plastics should be removed and discarded after each patient treatment.

For touch and transfer surfaces where barrier protection is not applicable or when barriers are compromised, please refer to A-dec's Equipment Asepsis Owner's Guide (P/N 85.0696.00) for recommendations on proper cleaning and chemical disinfection.

### Heat Sterilization

High volume evacuators (HVE), saliva ejectors (SE), and air/water syringes should be steam autoclaved between patients. The following protocol should be followed:

HVE - steam autoclave at 134°C (273°F), 6 minutes holding time

SE - steam autoclave at 134°C (273°F), 6 minutes holding time

Air/Water Syringe - steam autoclave at 134°C (273°F), 4 minutes holding time

Each handheld device with air and water lines should be discharged for 20-30 seconds between each patient to reduce the chance of cross-contamination as a result of potential bio-burden retraction.

## Specifications

Minimum air, water and vacuum service requirements for proper unit operation:

Air: 2.50 scfm (70.80 l/min) at 80 psi (551 kPa).

Water: 1.50 gpm (5.68 l/min) at 40 psi (276 kPa).

Vacuum: 12 cfm (339.84 l/min) at 8 inches of mercury (27 kPa).

Specifications are subject to change without notice.

## Conclusion

Thank you for taking the time to use the A-dec 500 Assistant's Instrumentation Owner's Guide. We would appreciate any feedback or comments you have about this document. Please mail, email or phone us with your comments. You can reach us at:

A-dec Inc.  
Technical Communications Department  
2601 Crestview Drive  
Newberg, OR 97132

Reach us by phone at:1-800-547-1883

email: [techcomm@a-dec.com](mailto:techcomm@a-dec.com)

website: [www.a-dec.com](http://www.a-dec.com)



#### A-dec Inc.

2601 Crestview Drive  
Newberg, OR 97132 USA  
Tel: 1-800-547-1883 within USA/Canada  
Tel: 1-503-538-7478 outside USA/Canada  
[www.a-dec.biz](http://www.a-dec.biz)

#### A-dec International Inc.

2601 Crestview Drive  
Newberg, OR 97132 USA  
Tel: 1-503-538-9471  
[www.a-dec.biz](http://www.a-dec.biz)

#### A-dec United Kingdom

Austin House, 11 Liberty Way  
Nuneaton, Warwickshire CV11 6RZ England  
Tel: 0800 ADECUK (233285) within UK  
Tel: 44 24 7635 0901 outside UK  
[www.a-dec.co.uk](http://www.a-dec.co.uk)

#### A-dec Australia

41-43 Bowden Street  
Alexandria NSW 2015 Australia  
Tel: 61 (0)2 9699 4600  
[www.a-dec.com.au](http://www.a-dec.com.au)

86.0603.00  
2006-6 Rev B (05318)  
©A-dec Inc. 2006  
All rights reserved